

Electric Eel[®]

MODEL C Dual Cable

Operator's Manual



!! DANGER !!

FOR YOUR SAFETY

Before you operate or maintenance this equipment, READ this manual carefully and completely!

Centenary **HIRE** .com.au

READ THIS MANUAL CAREFULLY.

With proper care and operation, your Model C Dual Cable Electric Eel will give you years of satisfactory service.

Description/Specifications

DESCRIPTION

The ELECTRIC EEL Model C Drain Cleaning Machine is typical of nearly half a century of ELECTRIC EEL's dependable, rugged, and versatile line of quality sewer and drain cleaning equipment. This machine is specifically designed for the professional when cleaning 3 to 10 inch diameter lines and using up to 200 feet of cable.

SPECIFICATIONS

- Line Capacity 3 to 10" dia. with up to 200 feet of cable.
- Weight 75 lbs.
(Machine only)
- Frame 1" open space framework of welded tube, with a cast Aluminum base.
- Tires 10" solid rubber.
- Power 1/2 HP Capacitor Start motor. (115 V AC standard), (Optional 3/4 and 1 HP, in addition, 220 Volt, 60 Cycle, and 230 Volt, 50 cycle are also available). Standard: 1 1/4" diameter x 8' cable sections.
- Optional J Cable 7/8" diameter x 6' sections.
- Controls 20 ft. cord assembly with reversing switch and built-in ground fault circuit interrupter, and momentary actuator switch with 15 ft. cord.
- Operator and Safety Manual
- Note All new units include cleaning tools, (as outlined on the top of page 8), plus one cable spanner wrench.

To obtain any additional information regarding the Model C Dual Cable Electric Eel, please write Electric Eel Manufacturing Company, Inc., Dept. R, 501 W. Leffel Lane, Springfield, Ohio 45501. Or contact us at 1-800-833-1212.

Safety Instructions

The following safety rules for operating ELECTRIC EEL the Model C Sewer and Drain Cleaning equipment **MUST** be read and followed carefully before operating this machine.

⚠ DANGER ⚠



To prevent serious injuries including:

- Shock, electrocution or burns due to improper grounding.
- Serious injuries to body, limbs or hands and feet due to cables that twist, kink and break.
- Eye injuries caused by loose cable, thrown debris or splashed water.

READ SAFETY INFORMATION THOROUGHLY!

⚠ DANGER ⚠

TO PREVENT SERIOUS BODILY INJURY AND AVOID DANGER FROM ROTATING CABLES AND EQUIPMENT:

GENERAL SAFETY

1. **ALWAYS** wear **HEAVY** reinforced leather gloves and **SAFETY** glasses when operating this equipment.
2. Place this machine within 8 feet of inlet, and **NEVER** add more than **ONE 8' SECTION** of cable at a time between sewer opening and machine.
3. **NEVER** handle rotating cable or cable under tension.
4. **DO NOT WEAR** loose clothing or jewelry while operating this machine.
5. The Model C Sewer and Drain Cleaning Machine should be **OPERATED BY ONE PERSON ONLY**. Additional personnel in the work area **MUST** observe all safety instructions.
6. Wear rubber soled **NON-SLIP SHOES, HEAVY LEATHER** gloves, and **EYE Protection**.
7. **ALWAYS AVOID** direct contact of skin, facial area and especially the **EYES** with drain water. Chemical compounds used in drains can result in serious burns and other injuries.
8. **REPLACE** fittings, cables, and any rotating parts as soon as they become visibly worn. **REPLACE** any cables which become fractured, bent, kinked, or are otherwise damaged.
9. **NEVER** attempt to service equipment beyond the recommendations of the operating instructions. All other servicing should be referred to qualified Electric Eel service personnel.
10. To maintain safe operation, **USE ONLY** identical replacement parts and cables from Electric Eel.
11. **ALWAYS KEEP CLEAR** of rotating shafts, pulleys, belts, or other rotating parts.
12. **DO NOT** continue to operate machine when cleaning tool becomes stuck in obstruction. **EXCESS TORQUE ON A CABLE COULD CAUSE IT TO FRACTURE. RELEASE CABLE TENSION** to prevent unnecessary build-up of torque on the cable. Keep machine under control at all times. (Refer to operating instructions to free cleaning tool).
13. **NEVER HANDLE ANY CABLE UNDER TENSION.* ALWAYS** relieve tension on the cable by reverse rotation or by turning the switch off and unplugging the cord.
14. **NEVER** force a tool and cable into pipeline blockage. This may overload the cable or tool and cause it to fracture.
15. Use **CORRECT TOOL** for the job or application. Check the tool chart and use the proper tool for the size of the line being cleaned.
16. To maintain safe and efficient operation **CLEAN THOROUGHLY** all cables and tools with water after use. Acids in the drain and sewer lines can attack and deteriorate the metal of the cables and tools. Deterioration can cause premature fracture or breakage in tools or cable.

*Relieve all tension build-up before attempting to handle cable.

DANGER
TO AVOID SERIOUS BODILY INJURY AND TO AVOID
DANGER FROM ELECTRIC SHOCK:
GENERAL SAFETY - ELECTRICAL

1. ALWAYS use a ground fault interrupted circuit with a properly grounded outlet for all electrical cords, connections and parts as installed by the factory. DO NOT make any alterations.
2. NEVER use machine while standing in damp or wet conditions.
3. NEVER expose machine to rain.
4. THE USER SHOULD NEVER ATTEMPT TO SERVICE THE ELECTRICAL COMPONENTS. For safety reasons all electrical replacement components should be installed by a qualified electrician.
5. BEFORE MAKING ADJUSTMENTS OR CHANGES TO POWER UNITS, DISCONNECT FROM ELECTRICAL SOURCE>

6. Then connect the proper tool to the first section of cable and insert it into the opening of the pipeline that is to be cleaned. If it enters the pipeline freely, feed it in by hand until an obstruction is met. Then, attach the cable to the machine. BEFORE TURNING ON THE MOTOR, BE SURE THE REVERSING SWITCH IS ON "FORWARD".
7. If the opening is trapped, you must use the feeding tool to start the cable into the line. The FEEDING TOOL is held against the rotating cable so that the cable feeds into the pipeline far enough to gain its own footing. Remove the starting switch from its bracket and use it and the feeding tool as shown in Figure 5.
8. As soon as the cleaning tool has negotiated the trap, shut off the motor and return the switch to the bracket. AVOID "P" traps in 3" diameter pipelines as they can cause severe cable damage. We recommend our Model J cables and cleaning tools for this application.
9. To add additional 8' cable sections use the following procedure, but NEVER add more than ONE 8' SECTION of cable at a time between sewer opening and machine. Feed the added section into the pipeline until the machine is two or three feet from the opening. Then add another length of cable. The open spaced, right hand wound construction of the outer cable member provides a self-feeding action and exerts an even pressure against the pipeline stoppage. If the safety clutch slips, put the machine in reverse and back away momentarily from the obstruction.
10. Work the cable back and forth—by alternating the motor in reverse and forward for a few seconds in each direction—until the initial opening in the obstruction is made. It is not necessary to let too much cable out of the line. A foot or two backward and forward several times usually does the job. Repeated slippage may indicate a broken or damaged pipeline. AVOID slack in the cable between the machine and the pipeline opening—as this is the area where cable will have a tendency to loop and then kink and become damaged and/or could cause serious injury.
11. Repeat this operation until flow is established. WHEN POSSIBLE, KEEP PLENTY OF FRESH WATER RUNNING THROUGH THE LINE WHILE WORK IS BEING DONE. This allows the obstruction, broken loose by the cleaning tool, to be flushed out. This also allows the cable to be washed off when it is withdrawn from the pipeline. It is important to wash off the cable in this manner—or with a hose—immediately after the job is completed. This prevents damage to the cable and tools by the chemicals present in drains and sewers.
12. After the initial opening is made, reverse the motor to feed the cable out of the line. Use the proper tool to complete the job.

Occasionally, a tool will hang up on some obstruction and will not feed back. If this happens, put the motor in forward rotation and pull back on the dolly until the tool is past the obstruction. Then, put the machine in reverse and the tool will feed out.

Operating Instructions



OPERATOR MUST BE THOROUGHLY FAMILIAR WITH ALL SAFETY INSTRUCTIONS BEFORE OPERATING THIS EQUIPMENT.

1. If at all possible, the nature and approximate location of the stoppage should be determined before starting the job. Usually a drain or sewer line obstruction is removed by running the cleaning tool downstream until the obstruction is reached.
2. The cleaning tool should be chosen according to the enclosed information for the line size being cleaned.
3. The cleaning tool reduces the obstruction to small pieces, which are then washed downstream by the flow of water. In such cases, after clearing the obstruction, you should use as much water in the line as possible.
4. Check for clean outs—and, where possible, avoid traps by using an opening beyond the trap.
5. Wheel the machine into the space where the work is to be done. Remove as many 8' sections of cable from the cable container as operating space will permit—and use a spanner wrench to separate the cables.

CLEANING TOOLS

The cleaning tools shown on the following page fall basically into two categories: (1) starting tools which have drill or spade points, and (2) finishing tools which usually are of a flat spring design with serrated edges. 3" and 4" diameter lines can usually be cleaned by using the starting tool to make the initial opening—and then using the finishing tool for the second run through the line.

Electric Eel Dual Cable Details



Figure 2 Separating cables with spanner wrench

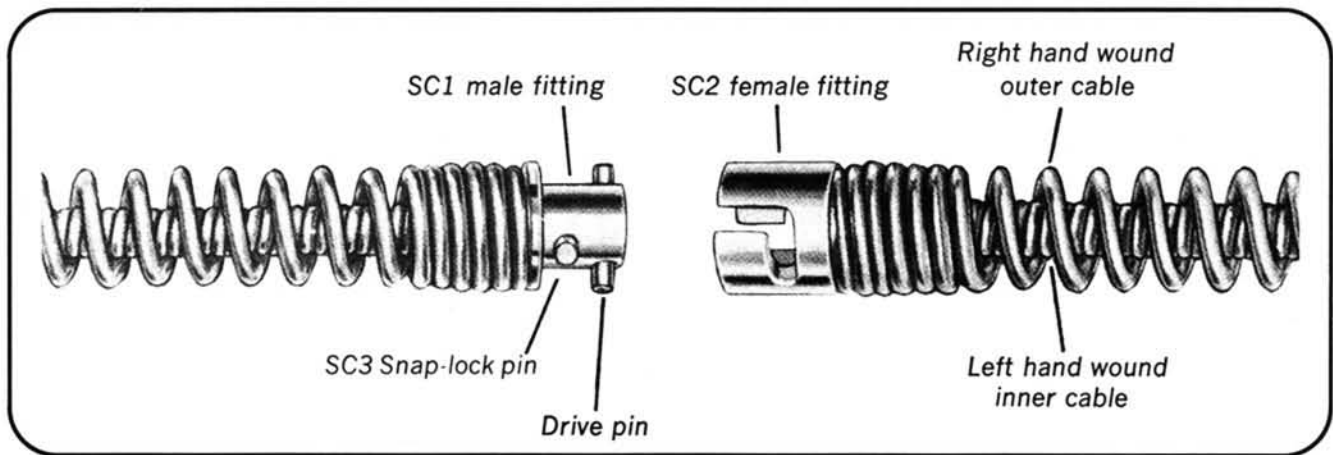

WARNING!
DO NOT HANDLE
ROTATING CABLE



Badly blocked pipelines usually require more than two runs through the line. Progressively larger cleaning tools should be used on each run until the line is cleaned to its original diameter.

EXAMPLE: A badly blocked 4" pipeline should be opened with the A-1DC tool. The HDD-3S tool should be used for the second run. The finishing run should be made with the HDD-4S tool—or with the A-14DC tool if entrance is made through a "P" trap.

Since the dual cable imparts a whipping action to the cleaning tool, the opening made in the pipeline obstruction is approximately 1/2" to 1" larger in diameter than the cleaning tool.



The Model C Electric Eel has a folding handle so that it may be easily transported and stored. You will find that this feature is also advantageous when you are working in crawl spaces.

